

FLOW-BOW - THE STRONG DEFLECTOR ELBOW

TO DEFLECT ABRASIVE BULK MATERIALS IN DENSE, PHASE MATERIAL CONVEYING PIPELINES



Optimal conduction of flow, wall thickness design and high-strength spheroidal cast iron, guarantee long durability and therefore low operating costs.

The Stanelle FLOW-BOW® elbow serves to deflect dry, non-clotting bulk materials with a highly wear-resistant system around corners in dense, phase material conveying pipelines. Areas of application are: from powdery and splintery materials to highly abrasive bulk materials, e.g. quartz sand, shotcrete, basalt chips, even animal body utilization. For applications in the plastics and foods industry special cast stainless steel (1.4408) models are available.

Areas of Application

- Stone-, Earth- and Mining industries
- Foundry technology
- Ceramics- and Glass industry
- Chemical- and food industry
- Animal utilization plants

The FLOW-BOW® is designed to build up a buffer layer of the abrasive material in the deflection elbow when conveying bulk materials. On this layer, the bulk material stream is deflected with very little wear. Because of the constantly changing buffer material cushion, the deflection area is still subject to abrasion. This area is therefore reinforced and the hard skin of the spheroidal cast iron provides additional abrasion protection. The material cushion is blown away completely by the final surge of the conveying stream. With soft bulk materials, such as for example marble, with a Morse hardness of less than 3, granule crumbling can occur in the cushion material.

Functionality

The graphic shows the wall thickness design and buffer material cushion in the FLOW-BOW®, through which an optimal wear protection is guaranteed.

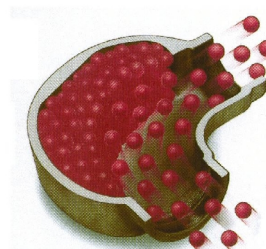

- Environmental due to less failures which could cause material loss
- Economical because of long service life
- Wear protection through optimal wall thickness design and material buffer cushion formation during dense phase conveying
- Wear resistant even with highly abrasive bulk materials
- FLOW-BOW® inlet and outlet sides can be varied and interchanged up to the DN 100 model; thus spare part costs are minimized if the worn flanges are replaced in time
- Simple installation and replacement due to optimal dimension and weight design

Details / Design

- Spheroidal or stainless steel cast iron (1.4408)
- Rust removal: SA 2,5
 Primer: 2K; 40µm
 Top coat: 2K; RAL 9006; 40µm

Finish

Dimensions for Flow Bow 90°, Flange/Flange-Connections

NW	40	50	65	80	100	125	150	175	200
PN	6	6	6	6 10	6 10	6 10	6 10	6 10	6 10
	10	10	10						
A	175	175	175	205	205	215	230	265	310
B	175	175	175	220	220	215	230	265	310
C	265	265	265	330	320	357	385	445	515
E	280	280	280	360	370	380	395	455	525
max. Width	150	150	150	230	230	220	240	320	390
D	130	140	160	200	210	250	285	315	340
	150	165	185		220				
K	100	110	130	150	170	200	225	255	280
	110	125	145	160	180	210	240	270	295
d ₂	14	14	14	18	18	18	23	23	23
	18	18	18		18				
n	4	4	4	4 8	4	8	8	8	8
	4	4	4		8				

All dimensions in mm, tolerances ± 2mm, flange dimensions ± 1mm

90° F/F

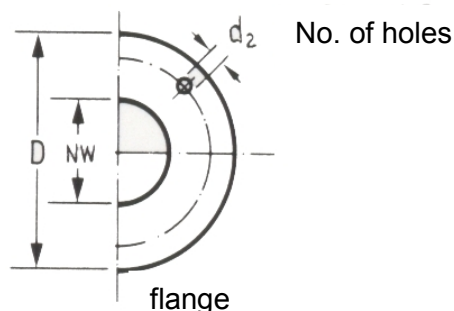
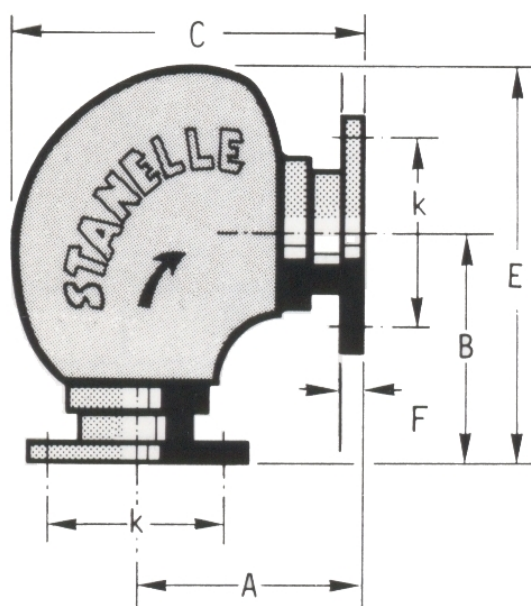

Dimensions Flow Bow 135°, Flange/Flange-Connections

NW	40	50	65	80	100	125	150	175	200
PN	6	6	6	6 / 10	6 / 10	6 / 10	6 / 10	6 / 10	6 / 10
	10	10	10						
A	123	123	123	197	197	183	190	198	205
B	295	295	295	352	352	442	460	477	495
C	250	255	260	272	350	300	320	325	365
	265	265	280						
E	340	345	365	370	425	510	530	550	590
	350	355	355						
max. Width	155	155	160	170	170	240	270	290	370
		165	185						
D	130	140	160	200	210	250	285	315	340
	150	165	185		220				
K	100	110	130	150	170	200	225	255	280
	110	125	145	160	180	210	240	270	295
d ₂	14	14	14	18	18	18	23	23	23
	18	18	18		18				
n	4	4	4	4 / 8	4	8	8	8	8
	4	4	4		8				

All dimensions in mm, tolerances ± 2mm, flange dimensions ± 1mm

135° F/F

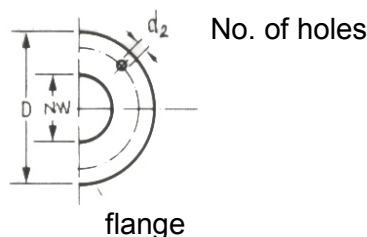
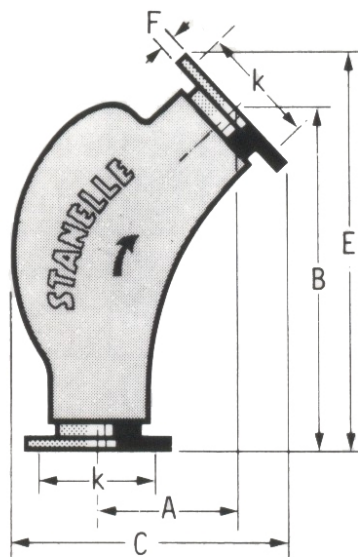

Combinations

Possible Combinations
90°

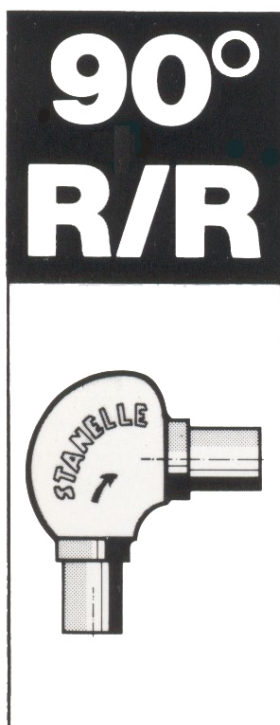

pipe / pipe

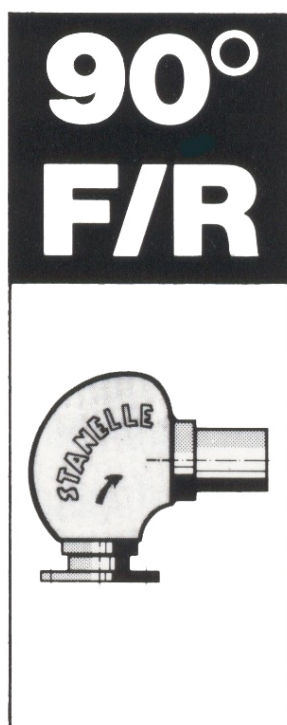

flange / pipe

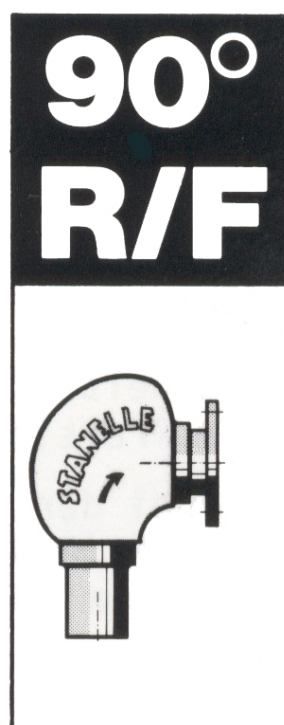

pipe / flange

90°

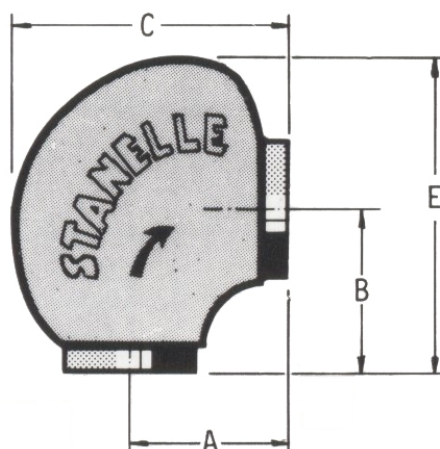

Thread	A	B	C	E
2 1/2"	120	120	210	225
4"	160	175	275	330

Housing 90°

All dimensions mm, tolerances ± 2mm

Combinations

Possible Combinations
135°

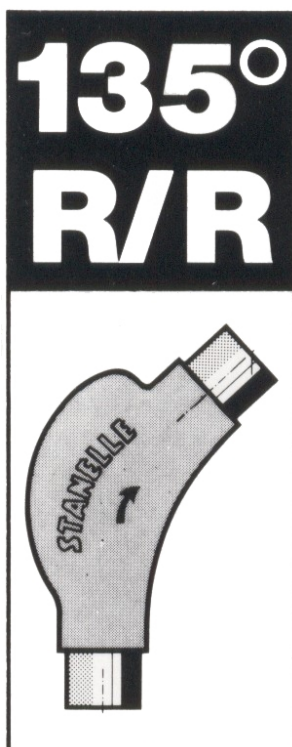

pipe / pipe



flange / pipe

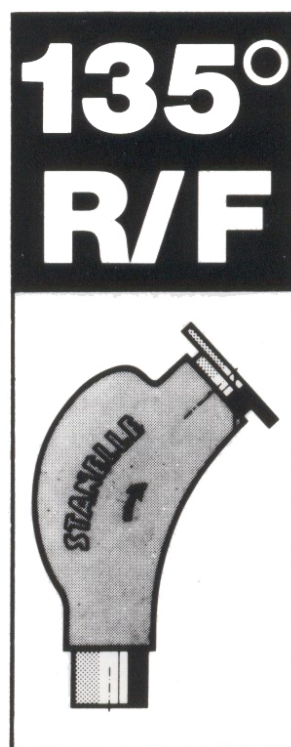

pipe / flange

135°

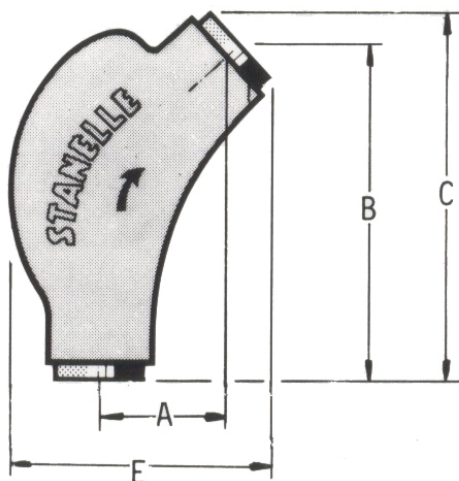

Thread	A	B	C	E
2 1/2"	85	200	235	198
4"	160	270	321	287

Housing 135°

All dimensions mm, tolerances ± 2mm

Dimensions Threaded Pipe

Thread	2 ½ "	4 "
NW	40	80
	50	100
	65	100
d1	48,3	88,9
	60,3	108
	76,1	114
S	2,6	3,2
	2,9	3,6
	2,9	3,6
L1	93	140
	87	115
	95	115
L2	70	90
	70	110
	70	110

Threaded Pipe

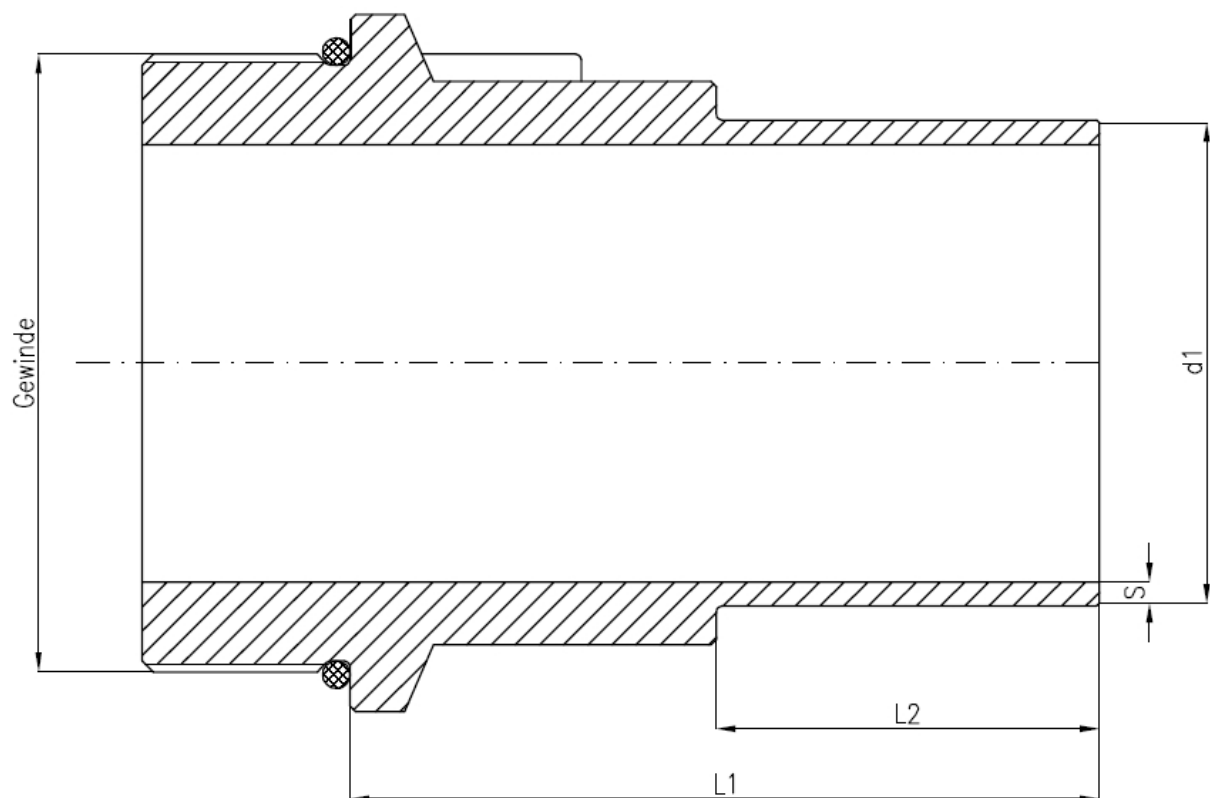

Dimensions Flange

Thread	2 ½ "		4 "	
NW	40		80	
	50		100	
	65			
L3	55		45	
	55		45	
	55			
PN	6	10	6	10
	6	10	6	10
	6	10	6	10
D	130	150	200	
	140	165	200	
	160	185		
K	100	110	150	160
	110	125	170	180
	130	145		
d2	14	18	18	
	14	18	18	
	14	18		
n	4		4	8
	4		4	8
	4			

All dimensions in mm, tolerances ± 2mm, flange dimensions ± 1mm

Flange

